

ASSEMBLY INSTRUCTIONS

DOUBLE CARTRIDGE

Exploded cartridge:

Item	Description
1p	Rotating contact surface product side
2p	Stationary contact surface product side
1a	Rotating contact surface atmospheric side
2a	Stationary contact surface atmospheric side
3	O-rings*
4	Springs*
5	Set screws *
6	Sleeve
7	Flange
8	Setting clips *
9	Flat gasket
10	Drive ring

* The quantity and sizes of that components is different depending on the model and size cartridge.

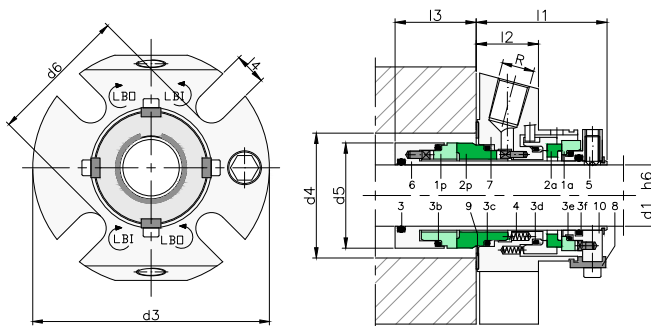

General instructions:

- Revise the catalogue to check that the technical features of the cartridge are suitable for the required application.
- Revise if the stuffing box dimension is appropriate according to the minimum values required in the catalogue.

- **Preparation:** **1.Shaft:** Ensure that there are no sharp edges over which the sleeve o-ring must pass.

Surface finish		Shaft outside diameter tolerance h6
Surface in contact with the elastomer	1 μ m	Shaft run out < 0.1 mm
Seat for the flat gasket	1.6 μ m	
Shaft end float < 0.13 mm		Squareness < 0,002 mm per shaft mm

- **2. Housing:** Ensure that the cavity is clean and free of dirt.

Installation instructions

The cartridge must be handle carefully. The assembly process is as follows:

1. Lubricate the shaft with soapy water to 3% of neutral soap. Lubricate also the screws and nuts of the pump.
2. Slide the cartridge onto the shaft into position. Fit the flat gasket into the stuffing box housing and ensure that it is in the correct position.
3. Tighten gland nuts down firmly
4. Equally tighten the Drive Screws down onto the shaft. To be sure the screws are fixed correctly, maximum hardness of shaft has to be 230 HB.
5. Remove setting clips and retain them for future use.
6. Spin the shaft by hand and feel for any shaft binding, etc. If so, set the setting clips again, loosen the drive screws and the gland nuts. Start over from step 2. If the noise is still experienced, check the shaft run out.
7. Connect the Quench & Drain. The dimension of the connections is: Typ LDC40 \varnothing 25mm à \varnothing 35mm-----1/4 NPT TAPON ALLEN 1/4 NPT \varnothing 38mm to \varnothing 100mm--- 3/8 NPT (TAPON ALLEN 3/8 NPT)
8. In a double cartridge is mandatory to connect an external fluid to cool the external seal. Ensure that the external fluid is present before start up.